

Hydraulic Pallet Truck & Foldable Pallet Mesh

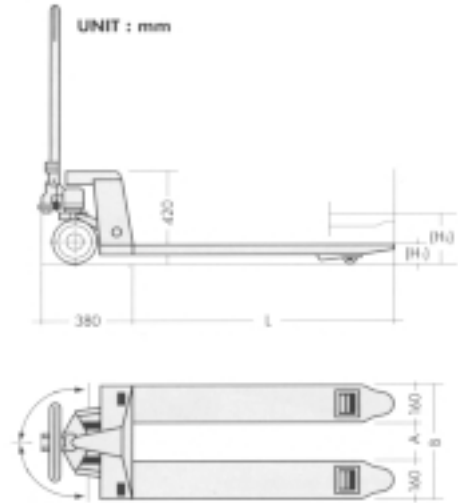

Order No	PT 25	PT 25NR	PT 25LB	PT 20LBNK	PT-ST20	PT-SC20
Load Capacity (kg)	2500		2000		2000	
Fork Height (lowered) - H ¹	85 mm		55 mm		85 mm	
Fork Height (raised) - H ²	200 mm		180 mm		200 mm	
Internal Fork Width - A	360 mm	230 mm	360 mm	220 mm	360 mm	352 mm
Overall Fork Width - B	680 mm	550 mm	680 mm	540 mm	680 mm	688 mm
Fork Length - L	1220 mm	1150 mm	1220 mm	1150 mm	1200 mm	1150 mm
Support Wheel (H x W)	40 x 45 mm (PU)		NIL		40 x 45 mm	
Load Wheel (H x W)	80 x 95 mm (PU)		50 x 60 mm (Steel)		80 x 95 mm	
Steering Wheel (H x W)	200 x 50 mm (PU)		180 x 50 (PU)		200 x 50 mm	
Fork Width	160 mm		160 mm		160 mm	168 mm
Height of Fork	60 mm		40 mm		60 mm	

Foldable Pallet Mesh

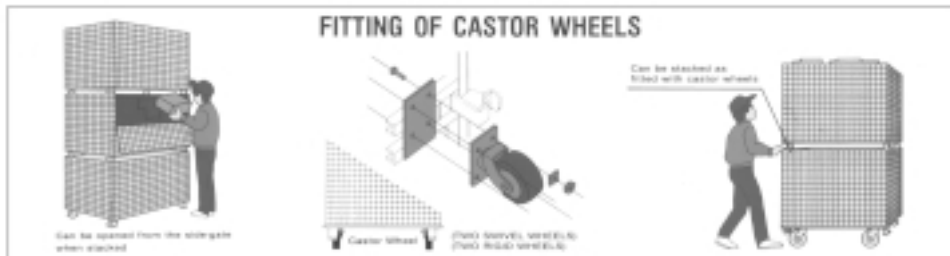
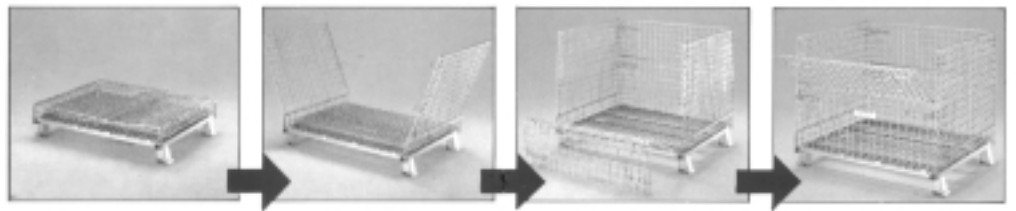

Order No	Capacity (kg)	No. of Layers	Size Outside (mm)			Mesh (mm)		Net Weigh (kg)	M ³
			Width	Length	Height	Diameter of Wire	Pitch		
FPM 3	800	4	600(24")	800(32")	640(26")	6.0	50	100(4")	0.22
FPM 5	1,200	4	800(32")	1000(40")	840(34")	6.0	50	100(4")	0.52
FPM 7	1,500	4	1200(40")	1200(48")	890(36")	6.0	50	100(4")	0.84